

# Macduff Robotics

Intelligent Subsea Equipment

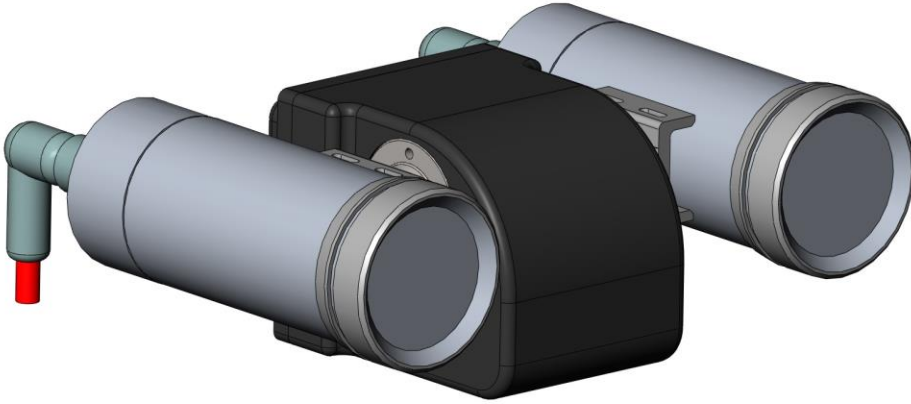

\*Cameras not included, shown here for illustrative purposes

## 24Vdc Electric tilt unit

### MAIN FEATURES

- Very low in water weight
- Reliable and low maintenance construction using brushless DC motors
- Simple controls
- Optional Serial control
- Overload protection
- Variable position limit switches
- Position feedback
- Dual camera mount

### Further Information

Spares kits also available

### Description:

A single axis rotator unit powered by a brushless DC motor for long-term reliable operation. Built using the highest quality gear assemblies and high reduction gearboxes and housed in a self-compensating oil filled Acetal body, this unit is corrosion resistant for long-term operation.

### Equipment supplied

Standard tool supply includes

- Tilt unit assembly
- Operating manual



info@macduff-robotics.com

## Specifications

Weight in Air	.....	TBC
Weight in sea water	.....	TBC

## Optional additions

- 

Information contained in this data sheet is up-to-date and correct as at the date of issue. All product designs, specifications and data are subject to change without notice to improve reliability, function, design or otherwise. No express or implied warranties are given.